

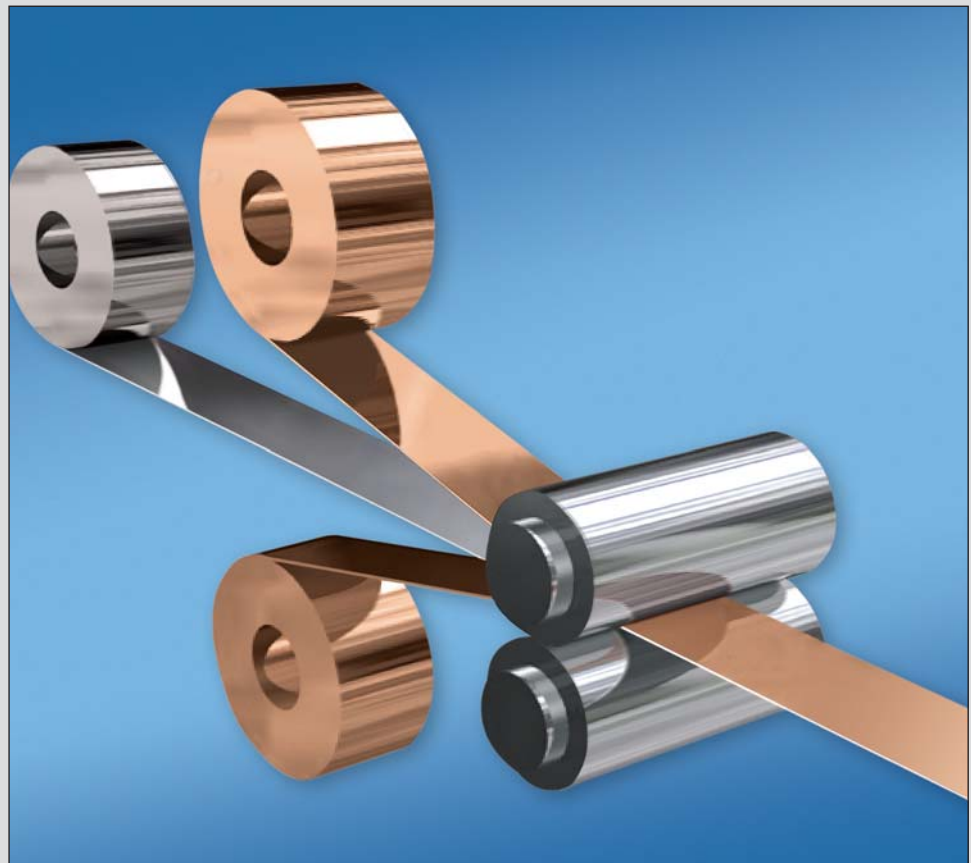

Publication 383 – E

## **Clad Steel Sheet and Plate**



**Stahl-Informations-Zentrum**

## Stahl-Informations-Zentrum

The Stahl-Informations-Zentrum is an organisation of steel producing and processing companies in Germany. It provides company-independent, market- and application-oriented information on the use and processing of steel.

**Various publications** in German language offer a wide range of practical guidance for designers, planners and processors. These guides are also used for educational and training purposes. Some publications are also available in English-language versions.

The Stahl-Informations-Zentrum also organises **lectures and international congresses** in which experts report on their experiences in steel applications.

At **trade fairs and exhibitions**, it presents the latest developments in steel and innovative uses of the material.

As a **special service** the centre also provides contacts with institutes, trade associations and experts from research and industry.

**Press work** focuses on supplying ongoing information to the trade and business media and daily press about new material developments and applications for steel.

The Stahl-Informations-Zentrum organises an award for innovations in steel. Presented every three years, the **“Stahl-Innovationspreis”** is one of the most important awards in the field ([www.stahlinnovationspreis.de](http://www.stahlinnovationspreis.de)).

The Stahl-Informations-Zentrum **website** ([www.stahl-info.de](http://www.stahl-info.de)) presents a wide range of information about steel, including upcoming events, as well as directory of all its publications. Information material can be ordered online.

## Publishing information

Publication 383 – E  
“Clad Steel Sheet and Plate”  
Edition 2006,  
published in English 2008  
ISSN 0175-2006

### Publisher:

Stahl-Informations-Zentrum  
P.O. Box 10 48 42  
40039 Düsseldorf, Germany

### Author:

Dr. rer. nat. Matthias Köhler  
58739 Wickede, Germany

### Editor:

Stahl-Informations-Zentrum

The greatest care has been taken in researching and compiling this publication. However, no responsibility can be accepted by the publishers or the compilers for the accuracy of the information presented.

This publication may not be reprinted in full or in part without prior written permission from the publisher. The source must always be quoted.

### Cover picture:

Schematic diagram of cold-roll bonding

## Contents

	Page
1 Introduction .....	3
2 Characteristics and applications of clad sheet and plate .....	4
2.1 Material properties .....	4
2.1.1 Influence of layer thickness .....	4
2.1.2 Thermal resistance .....	5
2.1.3 Chemical resistance .....	5
2.2 Application .....	5
2.2.1 Clad plates .....	5
2.2.2 Clad sheet and thin sheet ...	6
3 Production of clad sheet and plate .....	7
3.1 Bonding mechanisms .....	7
3.2 Hot-roll bonding .....	8
3.3 Cold-roll bonding .....	9
3.4 Explosion bonding .....	11
4 Inspection and testing of clad sheet and plate .....	12
5 Processing of clad sheet and plate .....	12
5.1 Forming .....	12
5.2 Cutting .....	12
5.3 Joining .....	12
6 Calculating the characteristics of clad sheet and plate .....	13
6.1 Physical properties .....	16
6.2 Mechanical properties .....	16
7 References and standards ...	17
8 Photo credits .....	17

### Member of the Stahl-Informations-Zentrum:

- AG der Dillinger Hüttenwerke
- ArcelorMittal Bremen GmbH
- ArcelorMittal Commercial RPS S.à.r.l.
- ArcelorMittal Duisburg GmbH
- ArcelorMittal Eisenhüttenstadt GmbH
- Benteler Stahl/Rohr GmbH
- Gebr. Meiser GmbH
- Georgsmarienhütte GmbH
- Rasselstein GmbH
- Remscheider Walz- und Hammerwerke Böllinghaus GmbH & Co. KG
- Saarstahl AG
- Salzgitter AG Stahl und Technologie
- ThyssenKrupp Electrical Steel GmbH
- ThyssenKrupp GfT Bautechnik GmbH
- ThyssenKrupp Steel AG
- ThyssenKrupp VDM GmbH
- Wickeder Westfalenstahl GmbH

## 1 Introduction

Clad materials are two- or multi-layer metallic composites that are finding increasing use wherever clear functional and/or economic advantages over a homogeneous material are achievable through a tailored combination of material properties. The material combinations primarily to be found are those in which steel, a sophisticated and inexpensive base material, ensures the required strength properties, while suitable cladding materials impart special physical, chemical or mechanical properties to the composite.

Clad materials nowadays are manufactured by a number of different bonding techniques that are distinguishable from one another by the shape and dimensions of the realisable semi-finished products, such as sheets, plates, strips, wires or tubes (**Figure 1**), by the spectrum of combinable materials, and by the realisable layer thickness ratios. All the

bonding and cladding techniques are based on bringing the partners together through intimate contact. The introduction of energy initiates restructuring processes in the contact zone at the atomic level that lead to the formation of an inseparable metallic bond.

The term “plating”, should be used with caution. Its use in the English-speaking world especially can lead to confusion as there it originally stands quite generally for the application of metal coatings, but today is used almost exclusively for galvanically or chemically deposited coatings. The German term “Plattieren” is therefore best translated into English as “cladding” and is generally not to be used for galvanic techniques. The term “electroplating” is equally to be avoided [1].

In the following article, the most significant group of clad flat products, quantitatively speaking, will receive closest attention. The data provided in this context can be applied directly

to more complex semi-finished material or workpiece geometries. The three most commonly used production techniques, namely hot-roll, cold-roll and explosion bonding, will be described. The focus in this regard will be on cold-roll bonding, which offers the most far-reaching possibilities for influencing the properties of semi-finished material and the end product.

Diverse new degrees of freedom in product design emerge as a result of the manifold combination possibilities that exist for clad sheet and plate. Also, the manufacturing technology has in most cases to meet different demands in comparison with homogeneous materials. The best material properties for an application are therefore best achieved through intensive dialogue between the semi-finished material producer and product designer/developer.

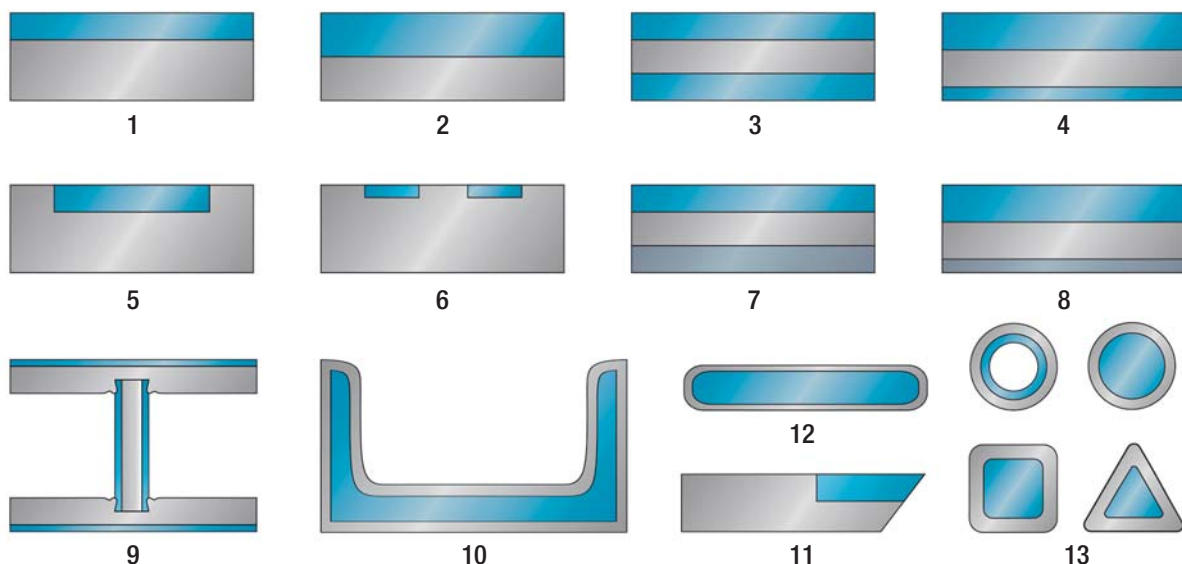

Figure 1: Products realisable by cladding

1–4 and 7–8: Clad sheet and plate (strip or cut-lengths)

5–6: Inlay claddings

9: DAVEX® profiles made from mechanically joined clad strips

10 and 12: Co-extruded clad profiles

11: Composite steel blades

13: Clad tubes and wires

## 2 Characteristics and applications of clad sheet and plate

### 2.1 Material properties

A distinctive feature of clad sheet and plate materials as multilayer metallic composites is that it is possible to ‘tailor’ required properties selectively through skilful selection of

the metals involved and their cladding thicknesses. The cladding process does not usually alter the characteristics of the individual cladding partners; the global properties of the composite are the product of the material combination in each case. The overview in **Table 1** shows the spectrum of conceivable goals when selecting a clad composite, as well as examples of use.

#### 2.1.1 Influence of layer thickness

Frequently when selecting a combination of materials for a special application it becomes necessary to strike a balance between contradictory property requirements. If, for example, a clad product comprising steel and copper is to be used to achieve high strength and good conductivity at the same time, it will be found that the composite lies between

Goals	Examples
<b>Mechanical properties:</b> e.g. strength, plastic deformation behaviour, elasticity, bending stiffness, torsional rigidity, tribological properties	<b>Copper on steel:</b> Combines the conductivity of copper with the strength or spring properties of steel Application: e.g. electrical contact components
<b>Physical properties:</b> e.g. specific weight, thermal expansion and curvature, electrical and thermal conductivity, magnetism, reflectivity	<b>Thermostat metal, e.g. FeNi36/Cu/NiMn2006:</b> Thermal curvature and electrical conductivity can be adjusted by suitably selecting the layer thicknesses Application: e.g. thermal protection switches
<b>Chemical properties:</b> e.g. corrosion resistance, co-reactants, catalytic properties	<b>Stainless steel* on steel:</b> Corrosion- or heat-resistant steel as protection against aggressive agents Application: e.g. chemical apparatus
<b>Metallurgical properties:</b> e.g. realisation of alloys through inward diffusion of clad materials into the base material	<b>Aluminium on corrosion-resistant steel:</b> Realisation of a pre-formable composite, production of heat-resistant but brittle iron aluminides on the surface by heat-treating the end component Application: e.g. fuel cells
<b>Processing/technological properties:</b> e.g. formability, properties for thermal or mechanical joining	<b>Self brazing clad materials, e.g. copper on corrosion-resistant steel:</b> Copper as the brazing filler material for a brazing process Application: e.g. oil coolers
<b>Aesthetics:</b> e.g. optical and haptic qualities of the surface	<b>Corrosion-resistant steel on aluminium:</b> Combines the bright surface of the corrosion-resistant steel with the low density of the aluminium Application: e.g. bumpers, wall facing elements
<b>Economic goals:</b> e.g. costs, material availability	<b>Titanium on steel:</b> Material with corrosion-resistant titanium surface less costly compared with homogeneous material Application: e.g. chemical apparatus
* Stainless steels, according to DIN EN 10088-1, 2005-9 edition, [2], include corrosion-resistant steels (formerly referred to as rust-proof steels) and heat-resistant and high-temperature steels.	

Table 1: Goals when selecting clad sheet and plate composites, including examples of use

the extreme values of the combined materials with regard to the two properties. It is therefore essential to find an optimum combination in relation to the desired property spectrum. For this purpose it is necessary to know the characteristics of the individual materials that are to make up the composite, as well as how the individual layer thicknesses will influence the finished clad product's characteristics. It also has to be borne in mind that the layered structure will naturally lead to differences in directional characteristics such as the conductivity parallel and perpendicular to the layer plane. These aspects will be addressed in closer detail in Chapter 6.

In addition to the bulk properties and thicknesses of the layers involved in the composite it is necessary, for closer consideration, to also take account of the influence that the bonding zone has on the clad composite. In some material combinations the formation of brittle alloy layers may negatively affect bond strength, formability, electrical or thermal conductivity, etc. It is however possible on the part of the clad sheet or plate producer to limit the thickness of such diffusion zones to orders of a few micrometers or less in most cases through optimisation of the process parameters, such that any influence on the bulk properties of the composite is usually negligible.

In some instances though such diffusion processes may be quite desirable. Cold-roll bonding, for example, opens up the possibility to produce well-formable "precursor" composite materials for difficult-to-form alloys. It requires being able to divide the alloy components between two or more precursors so that they have adequate ductility for cladding. If the precursors are united layer by layer as a composite by means of a cladding process, then the composite will have a greatly increased deformation potential compared with an equivalent alloy produced by a melt-metallurgical process. Once this precursor composite has been formed into the required final state (which may be a

component or also strip material), diffusion-induced "re-alloying" of the material then takes place in a final annealing treatment. The alloy components contained in the clad layers together form the desired difficult-to-form alloy with, ideally, identical properties compared with the equivalent produced by the melt-metallurgical process.

### 2.1.2 Thermal resistance

The behaviour of a clad product at high temperatures depends on two aspects in principle: on the one hand, on the property changes undergone by all the materials involved and, on the other hand, on their interaction. If a material pairing tends to form diffusion layers, then limiting conditions generally apply with regard to the temperature for using or processing the composite. In such a case the maximum admissible temperatures are selected in such a way that, over a required period, any growth of the alloy zones is limited to a still acceptable thickness or is completely avoided.

The hot gas corrosion behaviour is governed primarily by the resistance of a composite's outer layers under the ambient conditions prevailing at the time. Particular attention has to be paid, though, to cut edges and joints, which may need protection by means of special measures as described in Chapter 2.1.3.

### 2.1.3 Chemical resistance

The chemical resistance of a clad material's surface initially depends exclusively on the properties of the outer layers. If a certain abrasion of the claddings is expected under service conditions, then the cladding thicknesses have to be matched to the requirements so as to achieve the envisaged material service life.

The conditions in the region of cut edges are somewhat different,

however, as there the claddings no longer protect the inner layers. What is more, it is necessary to take electrochemical relationships into consideration since there is generally bi-metallic corrosion or cathodic protection effects at those locations. In the case of aluminium-clad mild steel grades, for instance, it is quite possible for a cathodic protection effect of the aluminium to influence the steel core, depending on the sheet/plate and coating thickness. As a rule, though, any contact of cut edges with corrosive agents must be precluded by means of suitable measures such as material-compatible designs, thus keeping unprotected edges structurally separate from aggressive agents (e.g. by flanging). Alternatively, a protective coating subsequently applied to exposed edges, such as by painting, thermospraying, etc., can also be considered.

## 2.2 Application

### 2.2.1 Clad plates

The fields in which hot-roll or explosion bonded plates find use are associated mainly with the manufacture of chemical apparatus such as corrosion-resistant pressure vessels, evaporators, heat exchangers or electrolysis equipment (**Figure 2**). In the petroleum industry, clad plates are utilised in the construction of pipelines and crude oil distillation plants. Other important applications include condensers and flue-gas desulphurisation systems of power plants, chemical tankers, foodstuff-related equipment, or seawater desalination plants. Corrosion-resistant cladding materials such as chromium-nickel steels, nickel-base alloys, pure nickel or titanium are typically combined with structural steels or with steels for pressure vessels as the base material. Given the high cost of the cladding materials, the use of clad plates in these fields represents an extremely cost-effective solution.

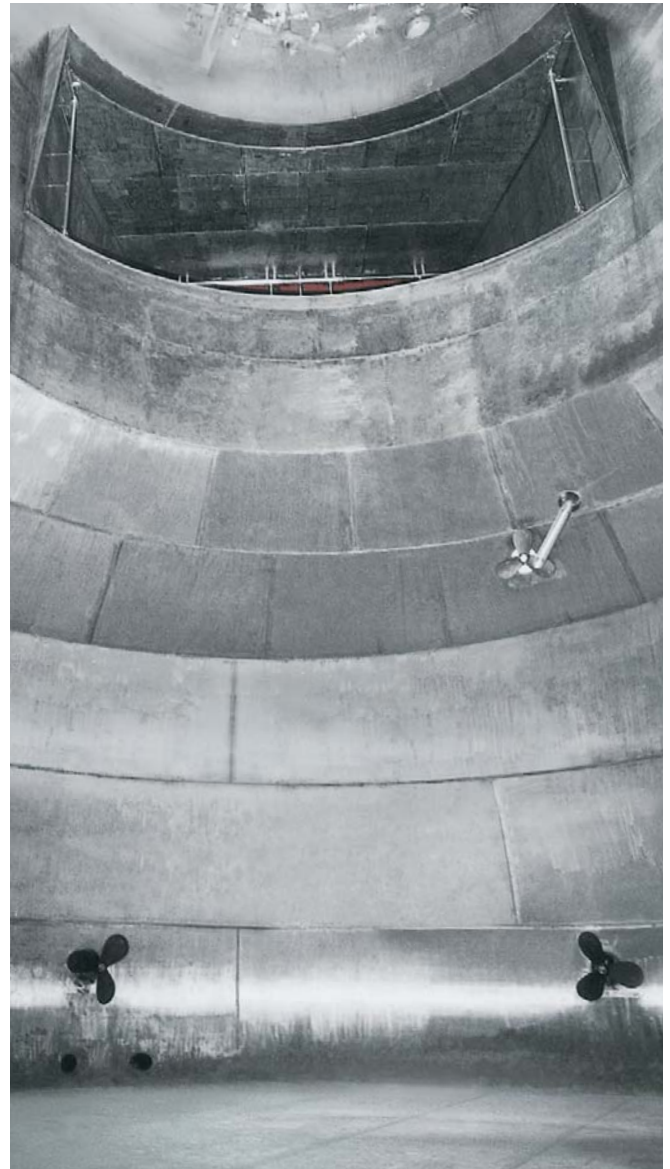

Figure 2: Examples of the uses of clad plate  
 Top: Inside view of a shell ring for a chemical reactor, clad with zirconium 702 low oxygen by explosion bonding  
 Right: Inside view of a flue-gas scrubber, clad with NiCr23Mo16Al by hot-roll bonding

### 2.2.2 Clad sheet and thin sheet

Clad sheet and thin sheet is predominantly material clad by cold-roll bonding. The main customers for such material include, in descending order, automobile makers and their component suppliers, the electrical and electronics industries, thermal engineering and power plant construction enterprises, coin and medal

manufacturers, and the household appliance industry [3]. The clad products in use comprise chiefly non-ferrous metals on mild steel grades (DC01-DC04), carbon steel (e.g. C60) or corrosion-resistant steel. While the steel core mostly ensures the strength properties of a composite, the cladding materials fulfil diverse functions such as providing corrosion protection, enhancing the electrical

or thermal conductivity, acting as a contact material or catalyst, improving wear resistance, serving as a brazing filler material, or achieving a desired appearance. **Figure 3** shows a few examples.



Automotive heat shield made of aluminium-clad steel sheet (DC01)  
**Properties:** corrosion-resistant, high reflection of thermal radiation

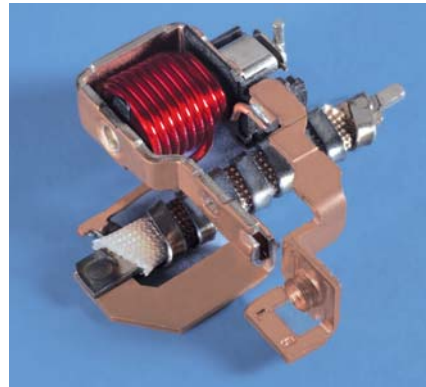

Electrical contact component made of copper-clad steel sheet (DC04)  
**Properties:** high strength, good conductivity, reduced cost



Automotive oil cooler made of copper-clad corrosion-resistant steel (X5CrNi18-10)  
**Properties:** copper functions as brazing filler material



Lighting canopy made of brass-clad steel sheet (DC04)  
**Properties:** high strength, decorative appearance

Figure 3: Examples of the use of cold-roll bonded materials

### 3 Production of clad sheet and plate

#### 3.1 Bonding mechanisms

The mechanisms that exert an effect in the bonding zone during the production of a clad composite depend quite significantly on the process used, the process parameters, and the metals that are to be joined together. To realise an inseparable metallic combination between two cladding partners, it is necessary to meet the following conditions:

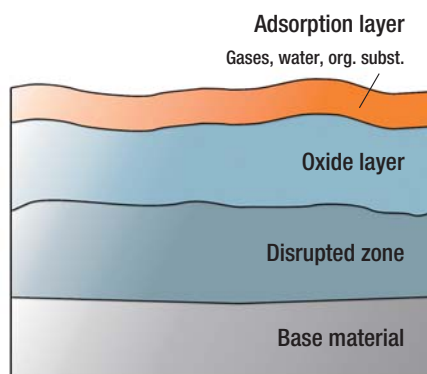

Figure 4: Surface structure of a metallic material

- **Interfaces have to be removed or broken through**

The surface of a metallic material characteristically displays a layered structure (Figure 4). The outermost layer is formed from gases such as oxygen or water vapour adhering to (adsorbed by) the material as well as from impurities like oil residues, etc. Located beneath this is generally an oxide layer. These layers cause the bonding capability of metallic surfaces to become saturated [4]. They have to be removed from the contact zone or broken through in order to form a composite. This can happen, for instance, through brittle oxide layers being torn open as a result of a forming process. Work hardening of near-surface material regions (referred to in Figure 4 as “disrupted zone”) can also be conducive to this process and where appropriate, therefore, is brought about intentionally in pretreatment processes.

- **Intimate contact between the cladding partners has to be established**

The surfaces that are to undergo joining have to be brought into intimate contact with one another that is at an atomic level over a broad area. This can happen through high pressure, for example, in conjunction with a forming process.

- **Restructuring processes in the bonding plane have to be initiated**

An inseparable composite can come about only if a transition layer forms between the bonding partners, e.g. through “diffusion”, via which a continuous adjustment of the material properties takes place (Figure 5). It brings about a reduction of internal stresses. Its formation however necessitates energy, which can be introduced by means of heat, for instance.

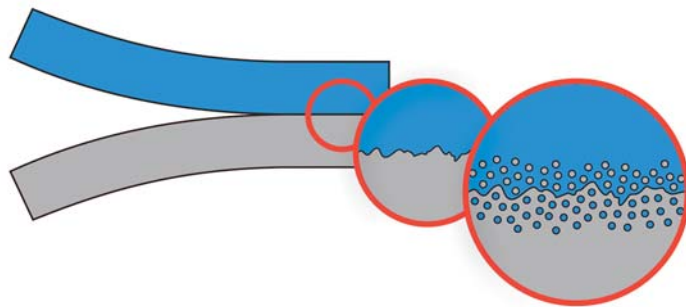

Figure 5: Composite solidly formed through diffusion processes in the bonding zone at the atomic level

• **Adhesion-reducing processes have to be avoided as far as possible**

If the metallic bond is to be brought about through exposure to heat, then it is necessary to adhere to annealing conditions that are precisely calculated for certain material combinations. It is thus ensured that the formation of brittle alloy layers, which may come about in the bonding zone as a result of diffusion processes, is avoided or limited to a non-critical level. Also, there is the possibility to use suitable intermediate layers or alloy components as diffusion barriers.

**3.2 Hot-roll bonding**

In hot-roll bonding, the fusion of base and cladding material takes place by means of a hot rolling process at temperatures above the recrystallisation threshold (Figure 6). For this purpose the materials that are to be joined are normally assembled as a package prior to rolling and hot-rolled as one complete unit. This rolling process takes place, as is customary in hot rolling, without any forward and back tension forces acting on the “rolled package” which, where materials with greatly differing forming properties are concerned,

would lead to bending of the in-process stock. For two-layer composites, therefore, two pairs of material are symmetrically assembled in each case, with a suitable interlayer serving to preclude any mutual adhesion. The surfaces that are to be joined together have to be scale- and oil-free. The thus assembled package is welded together gas-tight. The package is generally evacuated, i.e. any remaining air is pumped out, in order to avoid the formation of any new oxides in the bonding zone. After evacuation the packages are heated in suitable furnaces to a temperature that depends on the material, and are then rolled. The deformation-induced elongation of the materials creates new, oxide-free surfaces in the bonding zones, making direct metallic bonding of the partners possible. This bonding comes about at the same time through diffusion processes, which are activated by the temperature needed for the hot rolling deformation. A heat treatment tailored to the materials involved follows the rolling, to impart the desired microstructural properties. The package is then cut open at the edges along the previously made welds and

Figure 6: Schematic diagram of the hot-roll bonding process

- 1: Introduction of an interlayer between the cladding materials
- 2: Assembly of the cladding package
- 3: Welding together
- 4: Evacuation
- 5: Heating
- 6: Hot rolling
- 7: Trimming
- 8: Grinding
- 9: End product

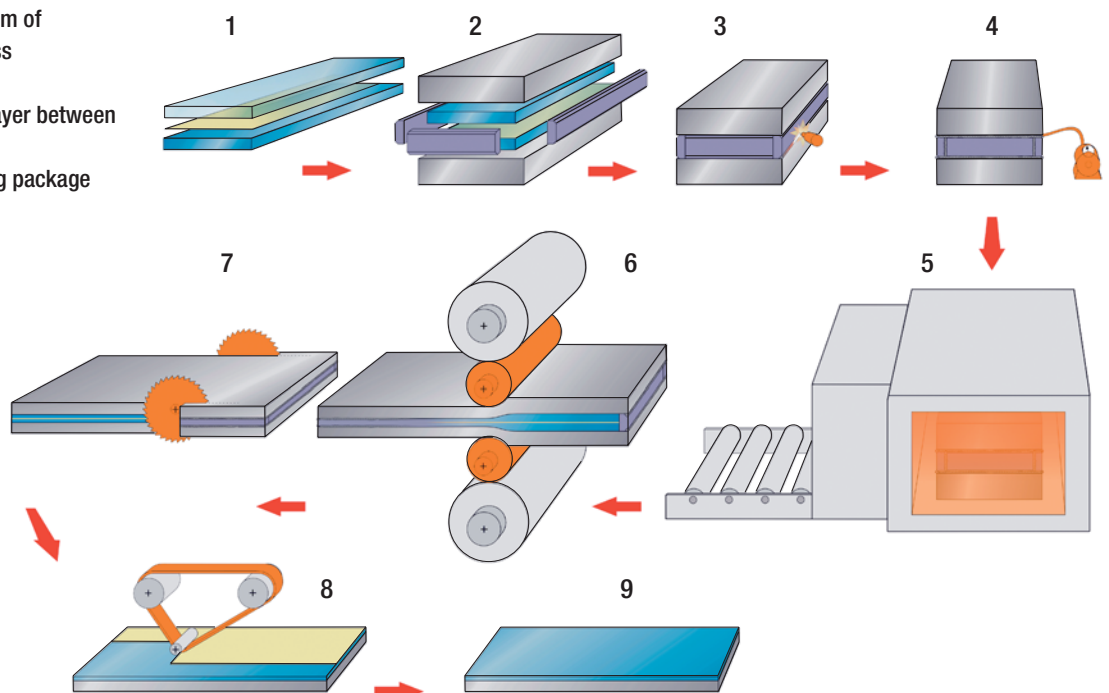



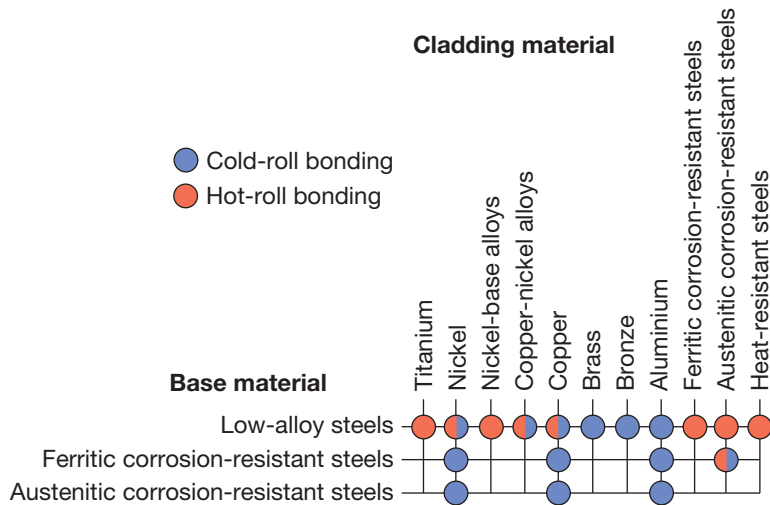

Figure 7: Common material combinations used for cold-roll bonded steel sheet and plate

inspected, in which respect an ultrasonic inspection is frequently conducted to verify the adhesion. The plates are also levelled in a final stage and, if necessary, freed of any scale and undesirable surface layers by means of grinding.

Hot-roll bonding is used predominantly to produce plates measuring 2.5 to 4 m in width, 10 to 12 m in length and over 150 mm in thickness. Hot-roll bonded composites can also be processed downstream however into thinner-gauge sheets and strips without affecting the thickness ratios of the individual layers achieved during the cladding process.

The selection of materials is confined to those with a similar melting point and not-too-dissimilar hot deformation behaviour. As the cladding package is exposed to relatively high temperatures in the process, hot-roll bonding is impractical for materials that tend to form brittle alloy layers, or is practical only if interlayers are used. In most cases conventional and fine-grain structural steels, steels for pressure vessels, shipbuilding steels or steels for piping engineering are used as base materials. Common cladding materials include corrosion- and heat-resistant steels, as well as non-ferrous metals and alloys

such as nickel-base alloys, pure nickel, copper, copper-nickel alloys, or titanium [5] (Figure 7).

### 3.3 Cold-roll bonding

Cold-roll bonding differs from hot-roll bonding in that its forming and diffusion processes take place separately from one another. In the first step, specially cleaned and pretreated strips of the materials due for cladding are cold-rolled together, i.e. at less than recrystallisation tempera-

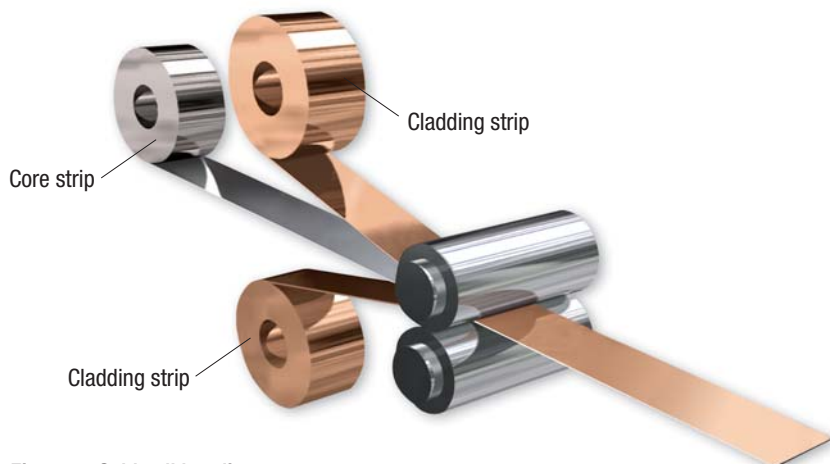

Figure 8: Cold-roll bonding

ture (Figure 8). This means having to achieve very large thickness reductions in one step. The adhesion thereby achieved, however, is still much weaker than the maximum achievable bond strength, which only final, so-called sinter or diffusion annealing can bring about. Mechanical separation of the joined metals is then no longer possible. Any later failure of the material, if adequately high stress is applied, will not therefore originate in the bonding zone, but in the weaker cladding partner whose shear strength thus limits the bond strength. An inseparable composite produced in this way can subsequently be cold-rolled like a homogeneous material, thus offering far-reaching possibilities to influence the dimensions, microstructural condition, strength levels and surface condition of the finished clad product.

The typical process involved in the production of a cold-roll bonded composite is shown in Figure 9. It comprises the following production steps:

- **Pretreatment**

The strips due for cladding are degreased and activated just before the cladding process typically by means of steel wire brushes to remove adsorption and oxide layers. Where some cladding materials are concerned (e.g. aluminium), it is possible to do without an activation process.

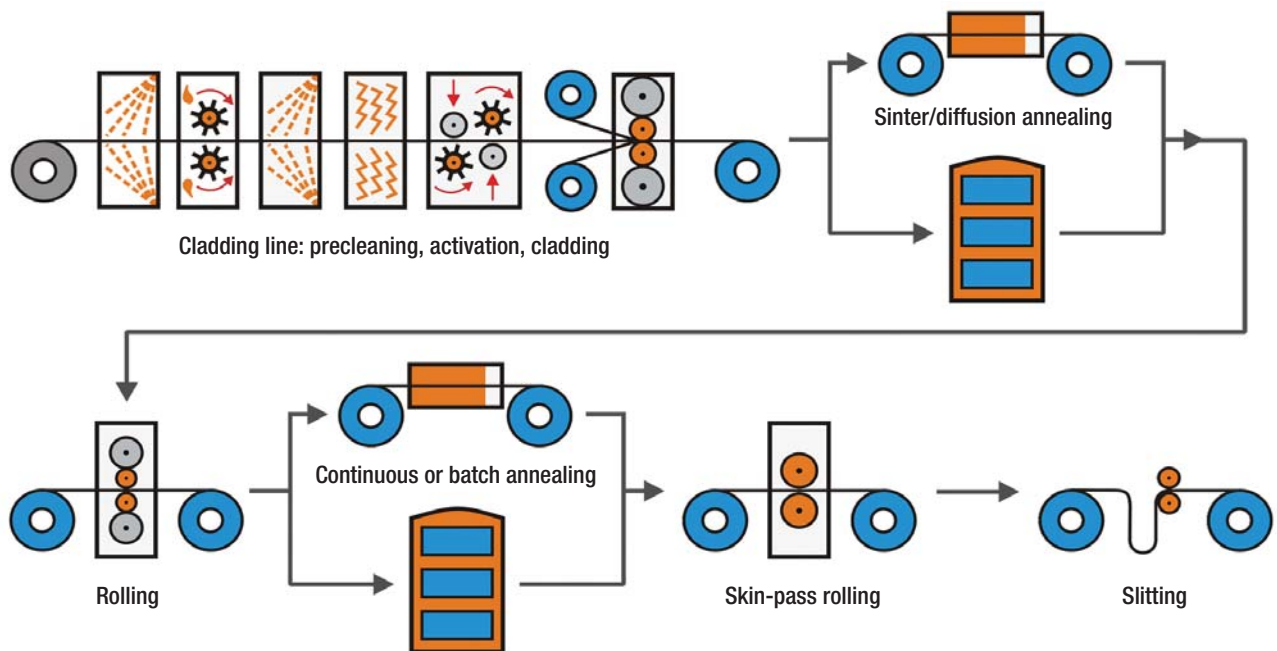

Figure 9: Process of cold-roll bonding

• **Cladding**

The core and cladding strips are cold-rolled together, it being necessary to achieve thickness reductions ranging from around 30% to over 60%, depending on the material combination. The appreciable accompanying elongation of the cladding partners tears open their brittle boundary layers in the bonding plane and, under exclusion of air, new and therefore highly active surfaces come about between the metals that are to be joined together. The great pressure necessary for this purpose brings the cladding partners into intimate contact with one another. Initial adhesion between the partners is created through adhesion forces, mechanical clamping measures and early onset of metallic bonding locally.

• **Sinter/diffusion annealing**

A heat treatment directly following the actual cladding process activates restructuring processes at the atomic level in the bonding planes, transforming those layers still not completely adherent after the cladding process into an inseparable composite (Figure 5).

With some material combinations, though, the adhesion generated during cladding is already so great that it is possible to do without sinter/diffusion annealing prior to further rolling. The parameters of the heat treatment process are optimised to the extent that any intermetallic layers that might occur are avoided or minimised. A recrystallisation of the materials extensively work-hardened by the cladding process normally takes place as a welcome side effect, thus restoring the deformation potential needed for the downstream processing of the material. Where combinations of high- and low-melting materials are concerned, it can happen that the melting temperature of one material lies below the recrystallisation temperature of another cladding partner. In such a case either the composite can be produced only in as cold-rolled execution or, by selectively influencing the process parameters during cladding, the work hardening induced in the higher-melting material can be limited to a degree that is acceptable with regard to the forming properties required at the time.

The following process steps (depicted in the lower half of Figure 9) typify the production of cold-rolled strip material:

• **Rolling/annealing**

In most cases the composite is rolled almost to final gauge following the diffusion anneal. This step takes place similar to the cold rolling of an homogeneous material, since the adhesion rules out any variation in the flow of the individual layers within the composite. A follow-on heat treatment serves to match the strength and microstructural properties of the end product to the requirements of the customer. Where very thin final gauges are concerned, it may be necessary to carry out more than one rolling/annealing cycle because of the high total reduction involved. For thicker final gauges, on the other hand, there is also the possibility to clad directly to final gauge and do without any subsequent rolling process.

- **Skin-pass rolling**

Finishing with a low degree of reduction makes it possible to relieve the material of yield point elongation perhaps occurring in the soft-annealed condition. At the same time it can impart certain surface finishes ranging from matt to bright by means of different roll roughness textures. If these characteristics are unimportant for the end product, then the skin-pass rolling step can be left out.

- **Slitting**

In the last step the material is normally slit to its final width and/or trimmed at the edges.

During the subsequent packing stage it is necessary to coordinate the corrosion measures, if any, to suit the properties of the materials used in the composite.

The extreme forces and torques required because of the high reduction ratios in cold rolling limit the range of strip dimensions realisable by cold-roll bonding to maximum widths of around 800 mm, while typical sheet thicknesses lie in the region of 0.05 mm (in special cases also less than this) to around 5 mm. The separation of reduction and diffusion annealing makes it possible to selectively influence the bond, which is why the spectrum of materials that can be combined with one another is incomparably greater than that for hot-roll bonding. Mainly steel sheet is used as the base material for cold-roll bonding. Figure 7 lists common material combinations.

### 3.4 Explosion bonding

Explosion bonding makes use of the high pressure generated by the detonation of an explosive to produce clad composites. It involves suitable pretreatment of the cladding partners (degreasing, grinding) and then the positioning of the cladding material at a close distance over the

base material (**Figure 10**). Thin angled metal strips serve as spacers that are later integrated in the cladding. A layer of explosive in powder form is deposited uniformly on the cladding material. When this is ignited from a suitable point, the cladding material buckles at the detonation front and is accelerated toward the base material, impacting against it at high velocity at an angle governed by the process parameters. This angle, in conjunction with the high kinetic impact energy, tears material from the surfaces and ejects it from the collision front. A jet of material thus forms, removing remaining oxides and impurities from the bonding zone. The high kinetic energy with which the materials collide and impact against one another additionally leads, in combination with the high pressure, to the formation of a firm metallic bond. Any melting of the materials takes place locally, at most. As the collision angle necessary to form the jet of material cannot yet develop below the ignition point, no adhesion comes about in a certain area about this point. This area is unusable and later removed. In the contact zone the surface layers evade the pressure and begin for a short time to flow in the direction of the detonation front, leading in the process to a diverse build-up and intermingling of near-surface layers and forming, as a result, a characteristic wavelike bonding zone (**Figure 11**). The wave fronts hence run perpendicular to the propagation direction of the collision zone at all times.

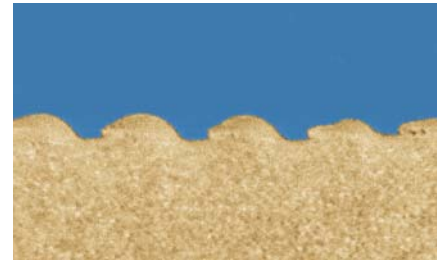

Figure 11: Wavelike bonding zone of a steel/titanium composite produced by explosion bonding

As the creation of the bond is activated by kinetic and not thermal energy during explosion bonding, no brittle intermetallic phases occur, either. This method hence offers the greatest variety of material combinations that can be clad to one another. The only precondition is that the cladding material is ductile enough to withstand the deformations occurring during explosion bonding. In practice, however, mostly the same material combinations as in hot-roll bonding are used because of the overlapping fields of application (Figure 7). The thickness of the cladding material in explosion bonding can range between 1 mm and 15 mm. The thickness of the base material is more or less unimportant. The lateral dimensions of explosion-bonded plates are theoretically unlimited where the process is concerned and are therefore confined to several metres only for reasons of handling and transportability.

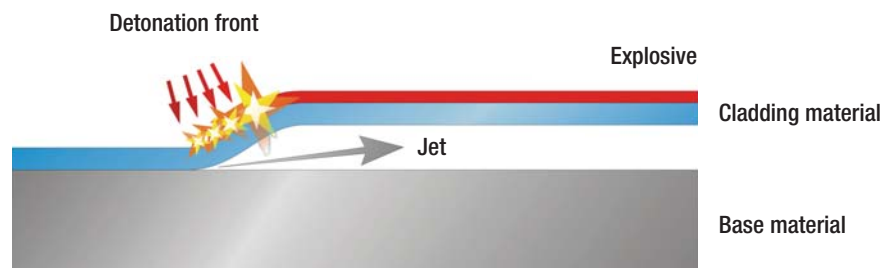

Figure 10: Schematic diagram of the explosion bonding process

## 4 Inspection and testing of clad sheet and plate

The mechanical properties of clad materials can be determined by means of conventional methods such as tensile testing, the Erichsen test, hardness measurement, notched-bar impact testing, the reverse bending test, etc. In the case of composites produced by rolling it is necessary, as with homogeneous material, to take account of a possible anisotropy of the properties in relation to the rolling direction. Hardness values of the individual layers can be ascertained by (micro)hardness measurements on the surface or in/on micrographs. Conventional microstructural analyses by means of micrographs are equally possible, it being necessary, when preparing the sample, to give consideration to the properties of the materials present in the composite.

Special attention has generally to be paid when testing the bond strength of the composite. Despite the high amount of time involved, very precise testing of the bond strength is required for the entire material, particularly for plates, in view of the materials' safety-relevant function in frequent cases. Ultrasonic testing has proven to be a successful method for this purpose [6]. It is unsuitable though for inspecting sheet and thin sheet materials produced by cold-roll bonding, for example, because the layer thicknesses are mostly too thin. Poor adhesion is, as a rule, identifiable to the naked eye, particularly if claddings are thin, such that a visual inspection complemented by adherence testing of random samples is normally sufficient in this regard. Diverse bending or torsion tests usually carried out until failure of the material allow a qualitative assessment of the bond strength. If adhesion is good, failure initially occurs in individual layers, but not in the bonding planes. A quantitative assessment of the bond strength is possible with the aid of various peel or shear tests. The effects of thermally induced shear forces on the bond can be

analysed by means of quench tests. The microscopic analysis of micrographs provides an additional reference point, as any diffusion layers or fine cracks in the bonding plane immediately become apparent.

## 5 Processing of clad sheet and plate

As far as processing is concerned, clad plates are formed and joined using the standard methods, similar to homogeneous material. Processability depends to a crucial extent on the materials in a clad composite, their properties and interactions. It is generally necessary, therefore, for a clad material to be individually suited to the downstream processing operations that are envisaged. Not infrequently there is a need to find a compromise between the properties desired in the end product and the processability of the finished clad product. In view of this as well as of the variety of possible material combinations, only general information on downstream processing can be provided at this point.

### 5.1 Forming

Clad materials, given the very good adhesion, are suited in principle to forming like homogeneous material. Changes in the relative layer thicknesses are not possible without destroying the composite. Standard and proven methods for forming clad sheet and plate include, for instance, rolling and bending and, in case of sheet and thin sheet, also deep-drawing, stretch-forming, hydroforming, or roll forming. The formability limit is generally contingent on the composite partner with the lowest deformation potential. Where the forming process is largely pressure-dominated, as in rolling, it must be borne in mind that in a composite made up of partners with greatly differing

strength levels softer materials tend to flow at an earlier point in time, inducing strong tensile stresses in more solid layers as a result of the adhesion. Such internal stresses can lead to the formability of the composite being limited, under pressure, by the fracture elongation of the most solid materials in the composite. It is, on the other hand, possible to influence the tribological properties of a clad material by selecting the cladding materials in such a way that there is an improvement in the forming behaviour.

### 5.2 Cutting

For mechanical cutting processes such as blanking or punching, as well as for machining techniques like drilling, milling, sawing and turning, it is necessary to tailor the various process parameters individually to the clad composite, which in case of high cladding thicknesses means a compromise between the process requirements of the materials involved. It is, on the other hand, quite possible to extend tool life substantially through optimised design of the clad composite.

If thermal cutting techniques are used, it must be ensured that any possible alloy formation in the region of the cut edge(s) does not have any negative effects on the required material properties. In case of laser machining, it may be necessary to apply suitably absorbent layers to the material beforehand if the cladding material, e.g. copper, has a high reflectivity in the infrared spectral range.

### 5.3 Joining

The use of finished clad products calls for careful selection of joining methods that are compatible with the materials involved. As it is principally a matter of joining different materials together, special attention

has to be paid to effects that may arise such as bi-metallic corrosion, thermal stresses, etc.

Mechanical joining methods such as riveting, flanging, clinching, etc. are suited to an especially broad spectrum of uses for clad sheet and thin sheet materials, provided that the composite has adequate formability.

If thermal joining techniques are to be used, it is generally necessary to take account of the clad material's thermal endurance. Any reduction in the strength of joints, for instance as a result of brittle intermetallic phases forming, has to be avoided.

It is possible to meet these requirements relatively frequently by means of diverse brazing methods. The efficiency of a brazing method can be significantly enhanced by having the brazing filler material in the form of a cladding layer. Copper, for example, is used to join corrosion-resistant steels. Materials that are

difficult to join by brazing can also be made easier to braze by means of a suitable cladding layer, with the cladding fulfilling the function of a transition material.

The weldability of clad composites depends to a very great extent on the materials involved and on the material thicknesses. Two-layer plates, for instance, can be welded on either side so that at any one time only base material is joined to base material, and cladding to cladding, thus largely avoiding any intermixing of both materials (**Figure 12**; see also [7] and [8]). This method is mostly difficult to apply any more to sheet materials. Where, in specific instances, material embrittlement due to alloy formation cannot be adequately minimised during welding through optimisation of the process parameters, there are in principle two possibilities for avoiding it. The cladding thickness of the composite can, on the one hand, be reduced

perhaps so that the embrittlement is kept within acceptable limits. There is, on the other hand, the possibility in most cases to remove interfering material from the weld region prior to welding. The missing material can, if necessary, be replaced later by thermal spraying, for example. If the intention is to join together different materials that are unsuitable for welding to one another, there is again the possibility to use a clad composite comprising the material partners as a transition material.

## 6 Calculating the characteristics of clad sheet and plate

Two aspects basically influence the properties of a clad composite: the materials that are to be combined, and their layer thicknesses. To achieve a desired property spectrum, therefore, it is necessary for the characteristics of the individual materials that are to be included in the composite to be known initially. Other influences, such as temperature, microstructural condition, etc. might also need to be taken into consideration. With this serving as a basis, it is first of all possible to calculate and optimise the overall characteristics expected of a finished clad product as a function of the individual layer thicknesses. Any subsequent "fine-tuning" of the material should be based on experimentally determined material properties.

The relationship between the overall characteristics of a clad composite, the properties of the materials contained in it and their layer thicknesses will be examined more closely in what follows, starting with simplifying model approaches. The resulting design formulae for estimating the physical and mechanical properties of clad plates are summarised in **Tables 2 and 3**. **Figure 13** explains the designation conventions used in them.

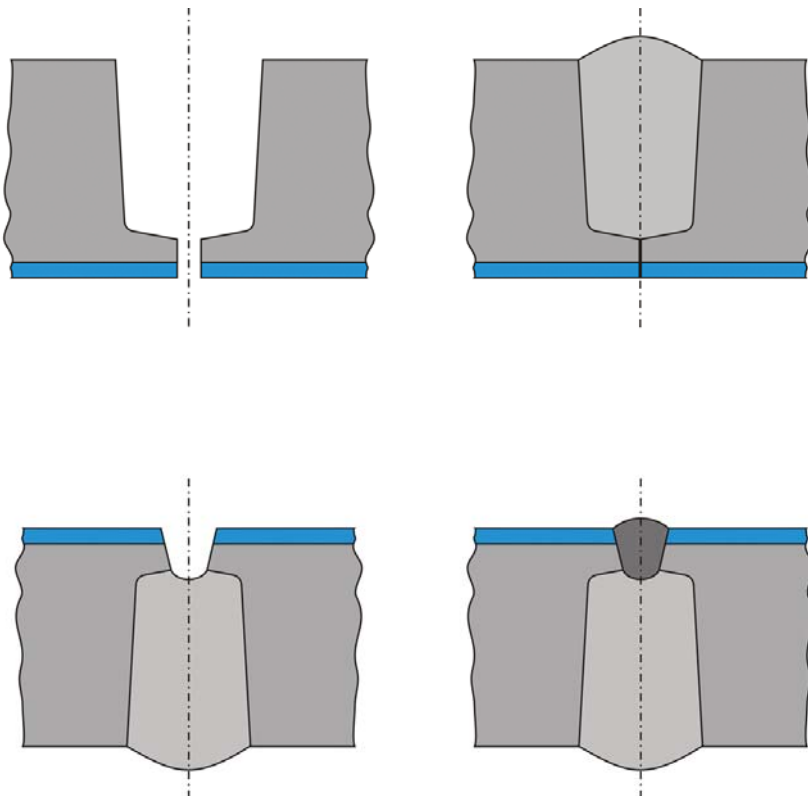

Figure 12: Welding of heavy clad plate layer by layer

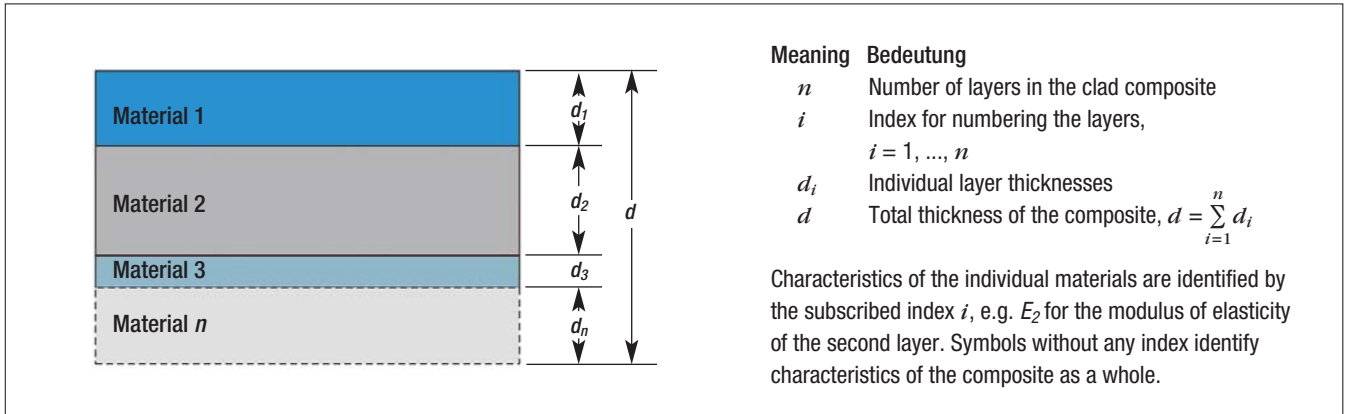

Figure 13: Designation conventions for a clad composite

Composite property	Formula	Unit	Symbols
Density	$\rho = \frac{1}{d} \sum_{i=1}^n d_i \rho_i$	g cm <sup>-3</sup>	$\rho_i$ Density of layer <i>i</i> [g cm <sup>-3</sup> ]
Specific thermal capacity	$c = \frac{\sum_{i=1}^n \rho_i d_i c_i}{\sum_{i=1}^n \rho_i d_i}$	kJ kg <sup>-1</sup> K <sup>-1</sup>	$c_i$ Thermal capacity of layer <i>i</i> [kJ kg <sup>-1</sup> K <sup>-1</sup> ] $\rho_i$ Density of layer <i>i</i> [g cm <sup>-3</sup> ]
Specific electrical conductivity parallel to the layer plane	$\sigma_{  } = \frac{1}{d} \sum_{i=1}^n \sigma_i d_i$	m Ω <sup>-1</sup> mm <sup>-2</sup>	$\sigma_i$ Spec. electr. conduct. of layer <i>i</i> [m Ω <sup>-1</sup> mm <sup>-2</sup> ]
Specific electrical conductivity perpendicular to the layer plane	$\sigma_{\perp} = \left( \frac{1}{d} \sum_{i=1}^n \frac{d_i}{\sigma_i} \right)^{-1}$	m Ω <sup>-1</sup> mm <sup>-2</sup>	$\sigma_i$ Spec. electr. conduct. of layer <i>i</i> [m Ω <sup>-1</sup> mm <sup>-2</sup> ]
Specific thermal conductivity parallel to the layer plane	$\lambda_{  } = \frac{1}{d} \sum_{i=1}^n \lambda_i d_i$	W m <sup>-1</sup> K <sup>-1</sup>	$\lambda_i$ Spec. thermal conduct. of layer <i>i</i> [W m <sup>-1</sup> K <sup>-1</sup> ]
Specific thermal conductivity perpendicular to the layer plane	$\lambda_{\perp} = \left( \frac{1}{d} \sum_{i=1}^n \frac{d_i}{\lambda_i} \right)^{-1}$	W m <sup>-1</sup> K <sup>-1</sup>	$\lambda_i$ Spec. thermal conduct. of layer <i>i</i> [W m <sup>-1</sup> K <sup>-1</sup> ]
Linear thermal expansion coefficient perpendicular to the layer plane	$\alpha_{\perp} = \frac{1}{d_0} \sum_{i=1}^n d_i^0 \alpha_i$	K <sup>-1</sup>	$d_0$ Original total thickness of the composite prior to change in temperature [mm] $d_i^0$ Original thickness of layer <i>i</i> prior to change in temperature [mm] $\alpha_i$ Linear thermal expansion coefficient of layer <i>i</i> [K <sup>-1</sup> ]
Total thickness of the composite resulting through thermal expansion perpendicular to the layer plane	$d = d_0 (1 + \alpha_{\perp} \Delta T)$	mm	$d_0$ Original total thickness of the composite prior to change in temperature [mm] $\alpha_{\perp}$ Linear thermal expansion coefficient of the composite perpendicular to the layer plane [K <sup>-1</sup> ] $\Delta T$ Magnitude of the change in temperature [K]

Table 2, part 1: Calculation of physical properties of clad materials

Composite property	Formula	Units	Symbols
Linear thermal expansion coefficient parallel to the layer plane  Good approximation applicable to $\alpha_i \Delta T \ll 1$ , while neglecting the thermal curvature	$\alpha_{  } = \frac{\sum_{i=1}^n E_i d_i \alpha_i}{\sum_{i=1}^n E_i d_i}$	K <sup>-1</sup>	$E_i$ Modulus of elasticity of layer $i$ [Pa] $\alpha_i$ Linear thermal expansion coefficient of layer $i$ [K <sup>-1</sup> ]
Total length of the composite resulting through thermal expansion in the layer plane (excl. curvature)	$l = l_0 (1 + \alpha_{  } \Delta T)$	m	$l_0$ Original length prior to change in temperature [m] $\alpha_{  }$ Linear thermal expansion coefficient of the composite parallel to the layer plane [K <sup>-1</sup> ] $\Delta T$ Magnitude of the change in temperature [K]
Thermal curvature of a bi-metal [9]	$\frac{1}{r} = \frac{6(\alpha_2 - \alpha_1)(1+m)^2 \Delta T}{d \left[ 3(1+m)^2 + (1+mn) \left( m^2 + \frac{1}{mn} \right) \right]}$	m <sup>-1</sup>	$m = \frac{d_1}{d_2}$ and $n = \frac{E_1}{E_2}$ $r$ curvature radius [m] $d_1$ thickness of the passive layer [m] $d_2$ thickness of the active layer [m] $E_1$ Modulus of elasticity of the passive layer [Pa] $E_2$ Modulus of elasticity of the active layer [Pa] $\alpha_1$ Lin. therm. expansion coeff., passive [K <sup>-1</sup> ] $\alpha_2$ Lin. therm. expansion coeff., active [K <sup>-1</sup> ] $\Delta T$ Magnitude of the change in temperature [K]
Specific thermal curvature of a bi-metal [10]	$k = \frac{1}{r} \frac{d}{\Delta T}$	K <sup>-1</sup>	$1/r$ Thermal curvature [m <sup>-1</sup> ] $d$ Total thickness [m] $\Delta T$ Magnitude of the change in temperature [K]

Table 2, part 2: Calculation of physical properties of clad materials

Composite property	Formula	Units	Symbols
Modulus of elasticity for elastic deformation parallel to the layer plane	$E_{  } = \frac{1}{d} \sum_{i=1}^n E_i d_i$	Pa	$E_i$ Modulus of elasticity of layer $i$ [Pa]
Curvature due to a bending moment	$k = \frac{1}{r} = \frac{M}{B}$	m <sup>-1</sup>	$r$ Curvature radius [m] $M$ Bending moment [Nm] $B$ Bending stiffness [Nm <sup>2</sup> ]
Bending stiffness of a sheet/plate	$B = b \sum_{i=1}^n E_i \left( y_i^2 d_i + \frac{d_i^3}{12} \right)$	Nm <sup>2</sup>	$b$ Sheet/plate width [m] $E_i$ Modulus of elasticity of layer $i$ [Pa] $y_i$ Centre distance of layer $i$ from neutral axis [m] $d_i$ Layer thickness $i$ [m]
Proof stress for tensile loading in the layer plane	$R_{p0,2} \approx \frac{1}{d} \sum_{i=1}^n d_i R_{p0,2 i}$	MPa	$R_{p0,2 i}$ Proof stress of layer $i$ [MPa]
Tensile strength parallel to the layer plane	$R_m \approx \frac{1}{d} \sum_{i=1}^n d_i R_{m i}$	MPa	$R_{m i}$ Tensile strength of layer $i$ [MPa]

Table 3: Calculation of mechanical properties of clad materials

## 6.1 Physical properties

- **Density**

As both the masses and the volumes of the individual layers are added together, the resulting density of the composite is the arithmetic mean of the individual densities, weighted by the respective layer thicknesses.

- **Specific thermal capacity**

The total thermal capacity is calculated in a similar way from the sum of the thermal capacities of the layers. The specific thermal capacity of the composite is hence the arithmetic mean of the specific thermal capacities of the individual layers, weighted by the respective densities and layer thicknesses.

- **Specific electrical conductivity**

Giving the specific conductivities for a composite makes sense only if a homogeneous current distribution in the individual layers is required. More complicated current distributions can be calculated with the aid of numerical methods (e.g. FEM). The conductivity becomes an anisotropic (i.e. directional) value due to the layer structure of the clad composite, as there is a parallel connection of the individual resistances in the layer plane and, perpendicular to this, a series connection.

- **Specific thermal conductivity**

The specific thermal conductivity behaves similarly to the specific electrical conductivity and again is, accordingly, an anisotropic value that in the steady-state case provides information about the homogeneous heat flux in the layers through the composite, parallel to the layer plane and perpendicular to it.

- **Thermal expansion and curvature**

When there are changes in temperature, the differing thermal expansion of the materials in a clad composite generates thermally induced internal stresses. The material as a whole reacts to this with deformations such that an equilibrium of forces including minimum elastic energy comes about. The expansion of the composite is again an anisotropic value due to the layered structure. The expansion perpendicular to the layer planes does not bring about any internal stresses in the free state and can therefore be calculated simply by adding up the expansions of the individual layers. If curvature of the material is excluded, for example due to symmetrical layer structure or external constraints, then a more or less linear thermal expansion coefficient of the composite parallel to the layers emerges. This is calculated by taking the arithmetic mean of the individual expansion coefficients, weighted by the moduli of elasticity and thicknesses of the respective layers. In the general case of an asymmetrical composite, a reduction of internal stresses takes place due to spherical curvature of the material, such that a greater elongation comes about in layers where there is greater thermal expansion. A narrow strip bends perpendicular to its longitudinal direction with negligible crossbow. Because of the altered stress field, the thermal expansion parallel to the layers deviates slightly from the value derived when disregarding the curvature. The curvature is easy to calculate (Table 2) for two-layer composites (e.g. thermostat metals). Where three or more layers and more complex component geometries are concerned, the behaviour in case of temperature changes can be determined with the aid of numerical methods (e.g. FEM).

## 6.2 Mechanical properties

- **Modulus of elasticity**

If there is elastic deformation parallel to the layer plane, the stresses in the clad composite layers are added together, making it possible to formulate an effective modulus of elasticity, again as a mean value, weighted by the layer thicknesses (Table 3). This value is not suitable for calculating bending or torsion of the material, however!

- **Bending stiffness**

The bending stiffness provides information about the elastic behaviour of sheet or plate material under the influence of a bending moment. The bending stiffness for a clad composite can be calculated with the aid of the parallel axis theorem (Table 3). The elastic reaction of complexly formed components to bending or torsion can be predicted with the aid of numerical simulations (e.g. FEM).

- **Proof stress and tensile strength**

The proof stress of a clad composite, when subjected to tensile loading in the layer plane, can be estimated with the aid of the following approach: by the time the proof stress is reached in tensile testing, plastic deformation has normally set in for all the metals involved in the composite, or the range of proportionality has at least been left, such that the stress-strain curves of the individual layers are relatively flat in comparison with the elastic region. The  $R_{p0,2}$  values of the cladding partners describe the acting stresses more or less correctly under this condition. The total stress is therefore defined by the mean for the proof stress values of the individual layers, weighted by the layer thicknesses. The tensile strength of a clad composite can similarly be estimated by taking the arithmetic mean of the ten-



sile strength values of the individual layers, weighted by the respective layer thicknesses.

Comparison with tensile tests reveals a relatively good concurrence with this model for many material combinations in most cases despite the greatly simplifying suppositions. The actual conditions in a composite where there is plastic deformation are, however, complex (yield point elongation, different transverse contractions, notch effects, shear stresses, etc.), which is why the formulae given in Table 3 should be used only for an initial estimation when designing a clad composite. FEM simulations and experiments provide more detailed information.

#### • Total elongation

To estimate the total elongation of a clad composite, the lowest total elongation value of all the materials involved (taking into account the microstructural condition and work hardening) should be used as a precaution. The other layers can be regarded as an additional safety margin. For clad materials comprising a thick core and thin claddings, it is possible to take the total elongation of the core material, with the claddings then providing a safety margin. It has to be borne in mind in this respect that cladding materials with lower total elongation values may have a notch effect on the core material that possibly leads to failure before fracture stress is reached. In which case actual values can again be determined only by means of tensile testing.

## 7 References and standards

- [1] Dettner, Heinz W.: "Lexikon für Metalloberflächen-Veredelung", 2<sup>nd</sup> enlarged edition, Eugen G. Leuze Verlag, 1989
- [2] DIN EN 10088-1, Edition: 2005-9  
Stainless steels - Part 1: List of stainless steels
- [3] Kawalla, R.; Schmidtchen, M.; Spittel, M.: "Plattieren - Eine Übersicht über Herstellungstechnologien und Produkte", In: Tagungsband MEFORM 2004, "Technologie der Werkstoffverbundherstellung durch Umformen", TU Bergakademie Freiberg, Freiberg 2004
- [4] Knauschner, A.: "Oberflächenveredeln und Plattieren von Metallen", VEB Verlag für Grundstoffindustrie, Leipzig 1978
- [5] Wödlinger, R.; Lettner, J.: "Plattiertes Grobblech - ein kostengünstiger Hochleistungswerkstoff", In: "Grobblech - Herstellung und Anwendung", Stahl-Informations-Zentrum, Dokumentation 570, 1<sup>st</sup> edition 2001, pp. 77-80
- [6] DIN 54123, edition: 1980-10  
Non-destructive Test; Ultrasonic Method of Testing Claddings, Produced by Welding, Rolling and Explosion
- [7] ISO/TR 17671-5, Edition: 2004-05  
Welding - Recommendations for welding of metallic materials - Part 5: Welding of clad steels

- [8] DIN EN ISO 9692-4, Edition: 2003-10  
Welding and allied processes - Recommendations for joint preparation - Part 4: Clad steels
- [9] "Thermobimetalle - Grundlagen, Berechnung, Gestaltung, Auswahl", G. Rau GmbH & Co., Pforzheim 1989
- [10] DIN 1715-2, Edition: 1983-11  
Thermostat metals; testing the specific thermal curvature
- [11] DIN EN ISO 12683, Edition: 2005-02  
Mechanically deposited coatings of zinc - Specification and test methods

## 8 Photo credits

The photos are published with kind permission of the following enterprises:

Figure 2, left:  
Deggendorfer Werft und Eisenbau GmbH

Figure 2, right:  
ThyssenKrupp VDM GmbH

Figure 11:  
DYNAenergetics GmbH & Co. KG

Remaining figures:  
Wickeder Westfalenstahl GmbH



**Stahl-Zentrum**

**Stahl-Informationen-Zentrum**

P.O. Box 10 48 42  
40039 Düsseldorf, Germany  
E-mail: [siz@stahl-info.de](mailto:siz@stahl-info.de)  
Internet: [www.stahl-info.de](http://www.stahl-info.de)